

6

5

4

3

2

1

## REVISION

ZONE	REV	DESCRIPTION	DATE	CHANGED BY	APPROVED
	1	INITIAL RELEASE	02/19/2024	HBAKKE	DREBECK

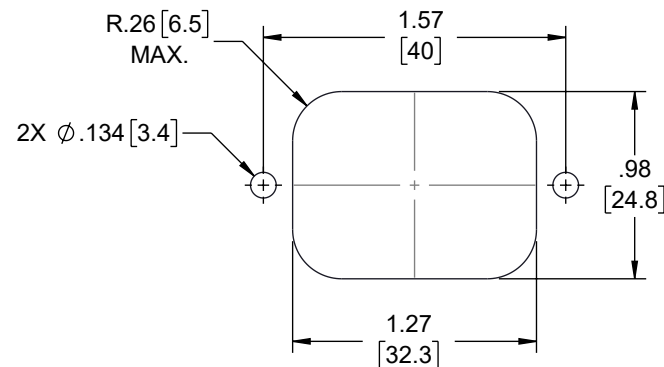
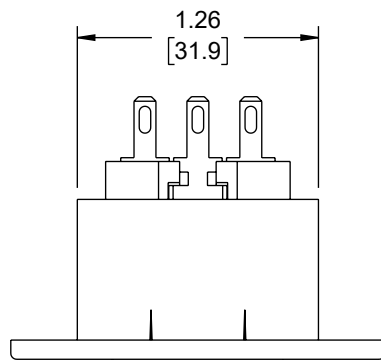

FIXING DETAILS

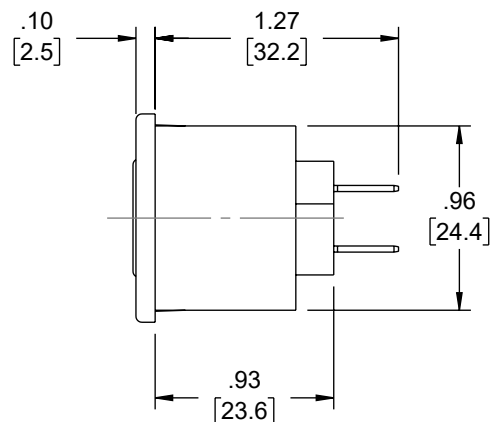
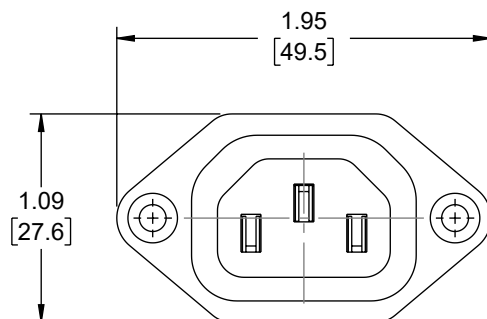

## NOTES:

- CONNECTOR TYPE: 60320-2-2/F
- RATING: 15A, 250V AC
- FEATURES: FLANGE MOUNT 2.8mm SOLDER TAB TERMINATIONS SHUTTERED
- PACKAGING NOTE:  
ITEM SHALL BE INDIVIDUALLY PACKAGED, LABEL PER LSP-010-5
- ALL DIMENSIONS FOR REFERENCE ONLY

THE INFORMATION CONTAINED IN THIS DRAWING IS THE SOLE PROPERTY OF INFINITE ELECTRONICS, INC. ANY REPRODUCTION IN PART OR WHOLE WITHOUT THE WRITTEN PERMISSION OF INFINITE ELECTRONICS, INC. IS PROHIBITED. THESE COMMODITIES, TECHNOLOGY OR SOFTWARE WERE EXPORTED FROM THE UNITED STATES IN ACCORDANCE WITH THE EXPORT ADMINISTRATION REGULATIONS. DIVERSION CONTRARY TO U.S. LAW PROHIBITED.

UNLESS OTHERWISE SPECIFIED  
LEADING DIMENSIONS ARE INCHES  
DIMENSIONS IN [ ] ARE MILLIMETERS

TOLERANCES:  
 .X = ±.2 [5]      FRACTIONS ± 1/32  
 .XX = ±.02 [0.5]      ANGLES ± 1°  
 .XXX = ±.005 [0.13]

CABLE LENGTH TOLERANCES:  
 ≤12 [305] = +1 [25] / -0  
 >12 [305] ≤ 60 [1524] = +2 [51] / -0  
 >60 [1524] ≤ 120 [3048] = +4 [102] / -0  
 >120 [3048] ≤ 300 [7620] = +6 [152] / -0  
 >300 [7620] = +5% / -0

ALL DIMENSIONS ARE FOR REFERENCE ONLY  
AND SUBJECT TO CHANGE WITHOUT NOTICE.  
UN-DIMENSIONED/NON-CRITICAL FEATURES  
MAY VARY IN SIZE AND LOCATION  
COLORS MAY VARY



an INFINIT@ brand

Website: [www.Transector.com](http://www.Transector.com)  
Phone: 1.800.882.9110 | 1.208.635.6400

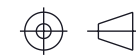

INTERPRET ALL DIMENSIONS AND TOLERANCES PER ASME Y14.5

SCALE	SHEET
NONE	1 OF 1

## DESCRIPTION

AC PEM 320-2-2/F PANEL FLANGE 2.8mm SOLDER TERMINALS SHUTTERED

SIZE	CAGE CODE	DRAWN BY	ITEM NO.	REV
A	30992	HBAKKE	ACM-2F-GSU-TT	1

6

5

4

3

2

1