

THE INFORMATION CONTAINED IN THIS DRAWING IS THE SOLE PROPERTY OF TRANSTECTOR, INC.. ANY REPRODUCTION IN PART OR WHOLE WITHOUT THE WRITTEN PERMISSION OF TRANSTECTOR, INC. IS PROHIBITED.

REVISION					
ZONE	REV	DESCRIPTION	DATE	CHANGED BY	APPROVED
	A	INITIAL RELEASE	04/19/2023	KGLEBOVA	GUTTADAURO

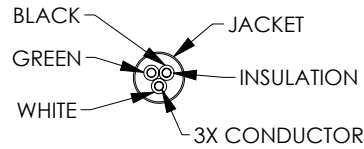
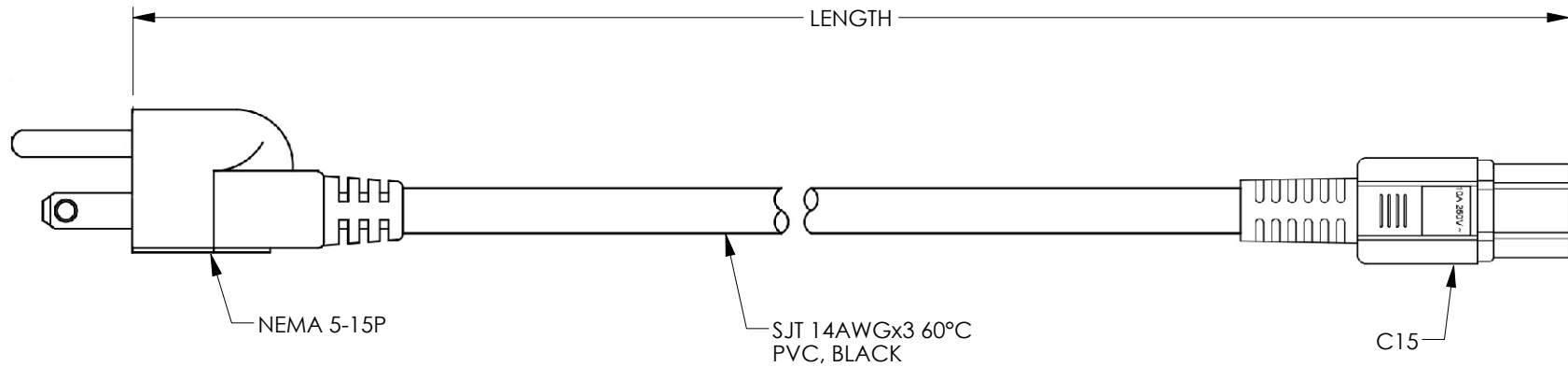

PART NUMBER	LENGTH FEET	LENGTH METERS
TTA00014-01F	1.0	.30
TTA00014-03F	3.0	.91
TTA00014-06F	6.0	1.83
TTA00014-10F	10.0	3.05
TTA00014-15F	15.0	4.57

NOTES:

- VOLTAGE RATING: AC  $\geq$  1500V/S
- CONNECTOR MALE POWER RATING: NEMA 5-15P UL-E257089
- CONNECTOR C15 POWER RATING: 15A UL-E257089
- CABLE: SJT 14AWGx3, 300V, 60°C VW-1 E313867 FT1
- CABLE ASSEMBLY SHALL BE INDIVIDUALLY PACKAGED.

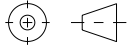
UNLESS OTHERWISE SPECIFIED, DIMENSIONS ARE IN INCHES [mm] OVERALL CABLE LENGTH TOLERANCE: ≤12 [305] = +1 [25] / -0 >12 [305] ≤60 [1524] = +2 [51] / -0 >60 [1524] ≤120 [3048] = +4 [102] / -0 >120 [3048] ≤300 [7620] = +6 [152] / -0 >300 [7620] = +5% / -0 ALL OTHER DIMENSIONAL TOLERANCES: .X = ± .2 [5]   FRACTIONS ± 1/32 .XX = ± .02 [5]   ANGLES ± 1° .XXX = ± .005 [13]	APPROVALS DRAWN BY: KGLEBOVA CHECKED BY: DFRISIELLO APPROVED BY: GUTTADAURO	DATE 04/06/2023 04/10/2023 04/12/2023	 an INFINITI® brand 10701 Airport Road, Hayden, ID 83835 Phone: 1.208.635.6400 Fax: 1.208.955.2041	CATEGORY <b>POWER PRODUCTS</b>	
	THIRD-ANGLE PROJECTION 	CONFIGURATION DETAILS OF UNDIMENSIONED FEATURES MAY VARY COLOR VARIATIONS MAY OCCUR			PRODUCT DESCRIPTION <b>PC/PDU POWER CORD - NEMA 5-15P TO C15 - 15Amp</b>
SCALE: NONE		SIZE: <b>A</b>	CAGE CODE: <b>30992</b>	ITEM NO.: <b>TTA00014-XXX</b>	REV.: <b>A</b>
CAD FILE: tta00014-xxx.SLDDRW			SHEET 1 OF 1		