

Installation Instructions

FSP 8002-MC, 8 WIRE PROTECTOR



an INFINIT[®] company

800.882.9110 | 208.772.8515 | www.transtector.com

Warning

1. These products are intended for indoor use only on Data circuits not to exceed 36V
2. Never install wiring during a lightning storm.
3. Failure to disconnect the data line at the network interface before installing the protector could cause shock due to contact with live voltages present on lines.

Thank you for your recent purchase of our surge protection solution. Your satisfaction with our product and service is important to us. If you have any questions, comments or concerns, please contact us at 800.882.9110 or visit our website at www.transtector.com. We look forward to continuing to serve your protection needs.

Installation Instructions

FSP 8002-MC Four Pair Card Reader Protector

1. Mounting (See Figure 1)
Mount the protector using the two (2) mount flanges, #6 screws or equal are suggested.

2. Wiring the FSP 8002-MC (See Figure 2)

2.1 All signal protection is bi-directional, with superior surge performance regardless of wiring source-destination or input-output directions. Install up to four (4) pairs of signals onto the appropriate terminal blocks, be sure to note the pair positions to keep all signals aligned. The terminals accept wire sizes from 12-28awg.

2.2 Connect the Ground stud to a system Ground. Ground lead must be connected to the lowest impedance earth conductor for proper suppressor operation. Use as large a wire size as is practical, 10awg minimum size is suggested, and as short a length as possible.

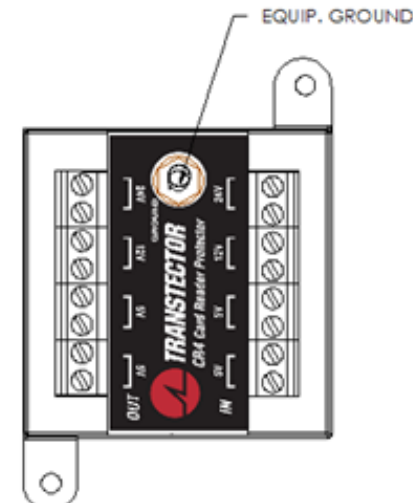
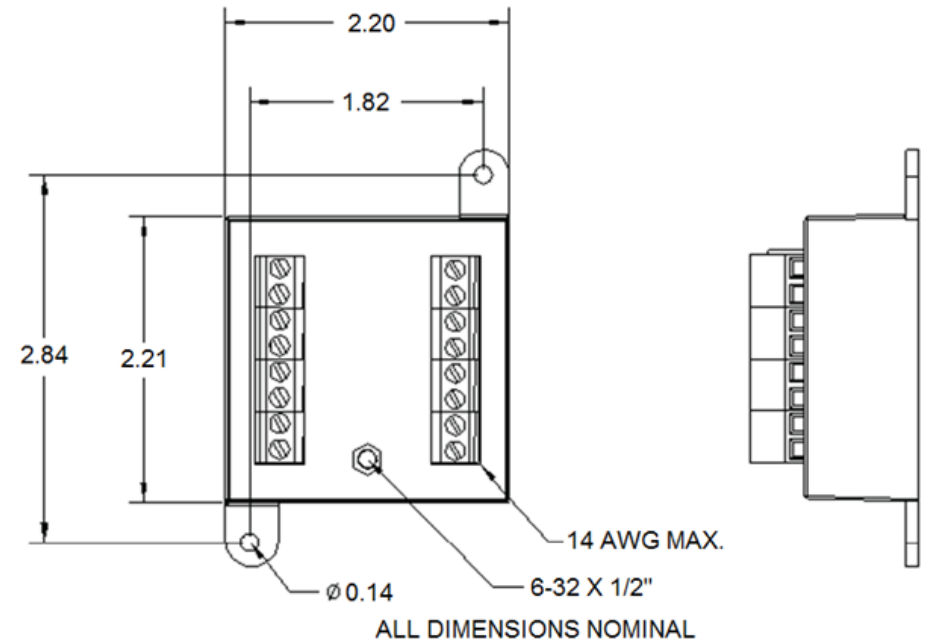

Figure 2