

## Installation Guide – AC Surge Protection

### I<sup>2</sup>R IEP 24 -5

Part# 1104-11-001



A Type 2 SPD with replaceable module for 24 Vdc systems. This SPD offers bidirectional silicon avalanche diode suppression technology and is typically installed to protect 24 Vdc power supplies from over-voltage caused by transients. The replaceable SPD module features visual status indication. The normally green indicator turns red if module needs replacement. Electrically isolated Form C dry contacts provide remote monitoring capability. If the lightning protection zone concept is used, this SPD installs at the boundary of LPZ1 and LPZ2.

Protection mode; V<sup>+</sup> - V<sup>-</sup>

### Main Technical Data

<b>Electrical Performance</b>	
Tested To	IEC 61643-1
Arrester Class	Class II, Type 2
Number Of Ports	Single port device
Technology	Silicon Avalanche Suppression Diode
Nominal Operating Voltage U <sub>n</sub>	24 Vdc
Maximum Continuous Operating Voltage U <sub>c</sub>	28 Vdc
Nominal Discharge Surge Current I <sub>n</sub> (8x20μs)	2.5 kA
Maximum Discharge Surge Current I <sub>max</sub> (8x20μs)	5 kA
Voltage Protection Level U <sub>p</sub> (6kV/3kA/8x20μs)	95V
Short Circuit Current Rating	22kA
Leakage Current	<10μA
Response Time	<5ns
Status Monitoring	Visual indication; Green = Normal, Red = Replace Contact Switch; Closed = Normal, Open = Replace
Contact Switch Rating	250 Vac / 3 A, 60 Vdc / 0.2 A
<b>Mechanical</b>	
Location Category	Indoor only
Method of Mounting	Fixed 35mm DIN rail
Dimension (H x W x L)	90mm x 18mm x 66.5mm (3.6" x 0.7" x 2.66")
Weight (Max)	0.33kg (0.74lb)
Maximum Wire Size	Stranded: 16mm <sup>2</sup> (#6 AWG); Solid: 25mm <sup>2</sup> (#4AWG)
Stripping Length Terminals	10mm (0.375")
Torque Terminals	4.5 N*m (3.3ft-lb)
Maximum Wire Size Contacts	1.5mm <sup>2</sup> (#16AWG)
Stripping Length Contacts	7mm (0.25")
Torque Contacts	1N*m (0.75ft-lb)
<b>Environmental</b>	
Operating Temperature	-40°C to +80°C
Relative Humidity	≤95% non condensing
Enclosure Protection Level	IP20
Housing Inflammability Rating	PA66; UL94 V-0
Certifications	RoHS compliant

The SPD provides a low impedance shunt path away from the equipment when a transient overvoltage occurs. In order to maximize the performance of the SPD, it is recommended to use insulated stranded copper greater than 10 mm<sup>2</sup> (#6 AWG) diameter, using lengths as short as possible and routed without any sharp bends. NOTE: Ensure that the ground wire, if used, is properly bonded to the local grounding system, or the SPD will not function properly. All conductors should be insulated stranded copper greater than 6 mm<sup>2</sup> (#10 AWG) minimum diameter. Further, the load capacity of the conductor must be sized according to the load. Reference IEC 60364-5-532.

## Installation Guide – AC Surge Protection

### Schematic

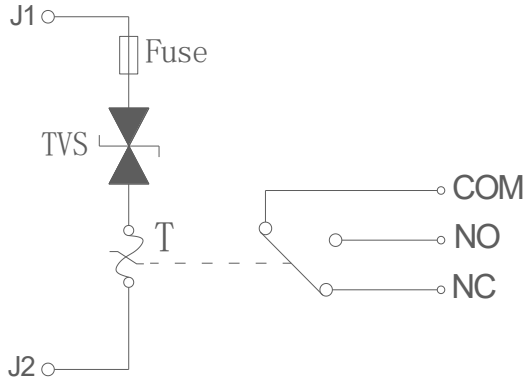

### Structure

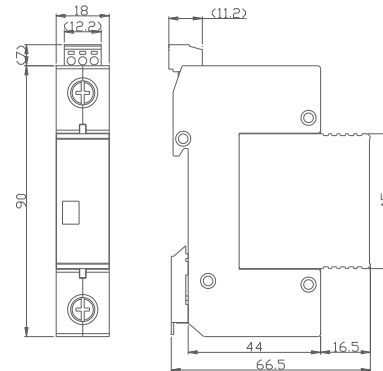

### Wiring Diagram

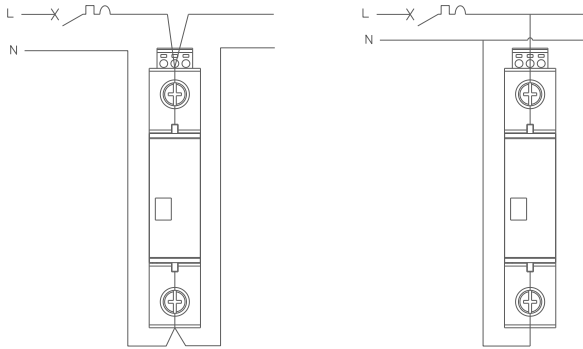

### Installation and Wiring

1. Install only in a restricted access power distribution cabinet that requires a key or tool to open.
2. The SPD should only be installed by a licensed electrician.
3. All local and national electric codes must be observed.
4. Kelvin or 'V' connections are recommended.
5. Keep wires as short as possible (maximum length  $\leq 0.5\text{m}$ ) and free of sharp bends.
6. Before installation, shut off power to prevent accidental electrical shock or injury.
7. The ground conductor should be insulated stranded copper greater than  $10\text{ mm}^2$  (#6 AWG) diameter. The power conductors should be insulated stranded copper greater than  $6\text{ mm}^2$  (#10 AWG) diameter. The load capacity of the conductor must be sized according to the load. Reference IEC 60364-5-532.

### Usage and Maintenance

1. The SPD should be scheduled for periodic inspection to ensure the SPD is operational, the module is secure in the base and all wire connections are tight.
2. To replace damaged SPD, contact +1.208.635.6400 or 1.800.882.9110, or online at [www.transtector.com](http://www.transtector.com).