

Specifications, Installation, and Operating Instructions

**Model: Power Vantage
AC Panel Protector**



CAUTION: The installation of a surge protection device (SPD) must be done by qualified electrical personnel. A SPD must be grounded through the power system ground for proper operation.

DANGER



WARNING: Before installing the suppressor, AC power must be OFF. Failure to do so could result in damage to the suppressor and poses a potential electrical shock hazard to personnel.



WARNING: Read SPD label on side of the enclosure to verify voltage configuration.



WARNING: Discontinue installation if the measured voltage is not in the range of the model voltage configuration of the SPD being installed. Contact LEA International technical support with any questions concerning the voltage configuration prior to installation and application of power.

Contents:

<u>TITLE</u>	<u>PAGE</u>
Specifications	3
Pre-Installation Notes	5
Mechanical Installation	5
Electrical Installation	6
Installation Procedure Checklist	8
Troubleshooting	8
Module Replacement Procedure	9
Wiring Diagrams	9

Part Number	Model: Type II SPD	Description	Fig. Ref.
B93-00-2040	PV-200-120/240-SP	Type 2, MOV 200 kA, 120/240 Vac, SP	1
B94-00-2040	PV-200-120/240-SP-D	Type 2, MOV 200 kA, 120/240 Vac, SP, Disconnect Switch	1
B93-00-4040	PV-400-120/240-SP	Type 2, MOV 400 kA, 120/240 Vac, SP	1
B94-00-4040	PV-400-120/240-SP-D	Type 2, MOV 400 kA, 120/240 Vac, SP, Disconnect Switch	1
B93-00-6040	PV-600-120/240-SP	Type 2, MOV 600 kA, 120/240 Vac, SP	1
B94-00-6040	PV-600-120/240-SP-D	Type 2, MOV 600 kA, 120/240 Vac, SP, Disconnect Switch	1
B93-00-2140	PV-200-120/208-3Y	Type 2, MOV 200 kA, 120/208 Vac, 3Y	2
B94-00-2140	PV-200-120/208-3Y-D	Type 2, MOV 200 kA, 120/208 Vac, 3Y, Disconnect Switch	2
B93-00-2740	PV-200-277/480-3Y	Type 2, MOV 200 kA, 277/480 Vac, 3Y	2
B94-00-2740	PV-200-277/480-3Y-D	Type 2, MOV 200 kA, 277/480 Vac, 3Y, Disconnect Switch	2
B93-00-4140	PV-400-120/208-3Y	Type 2, MOV 400 kA, 120/208 Vac, 3Y	2
B94-00-4140	PV-400-120/208-3Y-D	Type 2, MOV 400 kA, 120/208 Vac, 3Y, Disconnect Switch	2
B93-00-4740	PV-400-277/480-3Y	Type 2, MOV 400 kA, 277/480 Vac, 3Y	2
B94-00-4740	PV-400-277/480-3Y-D	Type 2, MOV 400 kA, 277/480 Vac, 3Y, Disconnect Switch	2
B93-00-6140	PV-600-120/208-3Y	Type 2, MOV 600 kA, 120/208 Vac, 3Y	2
B94-00-6140	PV-600-120/208-3Y-D	Type 2, MOV 600 kA, 120/208 Vac, 3Y, Disconnect Switch	2
B93-00-6740	PV-600-277/480-3Y	Type 2, MOV 600 kA, 277/480 Vac, 3Y	2
B94-00-6740	PV-600-277/480-3Y-D	Type 2, MOV 600 kA, 277/480 Vac, 3Y, Disconnect Switch	2
B93-00-2830	PV-200-480-3D	Type 2, MOV 200 kA, 480 Vac, 3D	3
B94-00-2830	PV-200-480-3D-D	Type 2, MOV 200 kA, 480 Vac, 3D, Disconnect Switch	3
B93-00-4830	PV-400-480-3D	Type 2, MOV 400 kA, 480 Vac, 3D	3
B94-00-4830	PV-400-480-3D-D	Type 2, MOV 400 kA, 480 Vac, 3D, Disconnect Switch	3
B93-00-6830	PV-600-480-3D	Type 2, MOV 600 kA, 480 Vac, 3D	3
B94-00-6830	PV-600-480-3D-D	Type 2, MOV 600 kA, 480 Vac, 3D, Disconnect Switch	3
Part Number	Model: Type I SPD	Description	Fig. Ref.

B93-00-2141	PV-200-120/208-3Y-1	Type 1, MOV 200 kA, 120/208 Vac, 3Y	2
B94-00-2141	PV-200-120/208-3Y-1-D	Type 1, MOV 200 kA, 120/208 Vac, 3Y, Disconnect Switch	2
B93-00-2741	PV-200-277/480-3Y-1	Type 1, MOV 200 kA, 277/480 Vac, 3Y	2
B94-00-2741	PV-200-277/480-3Y-1-D	Type 1, MOV 200 kA, 277/480 Vac, 3Y, Disconnect Switch	2
B93-00-4141	PV-400-120/208-3Y-1	Type 1, MOV 400 kA, 120/208 Vac, 3Y	2
B93-00-4741	PV-400 277/480-3Y-1	Type 1, MOV 400 kA, 277/480 Vac, 3Y	2
B94-00-4741	PV-400 277/480-3Y-1-D	Type 1, MOV 400 kA, 277/480 Vac, 3Y, Disconnect Switch	2
B93-00-6741	PV-600-277/480-3Y-1	Type 1, MOV 600 kA, 277/480 Vac, 3Y	2

Specifications

All Models

Features	Thermally Protected MOV Alarm with Disable Switch Internal/External Indicators Lights Surge Counter Form C contacts (NO & NC) EMI/RFI Noise Filtering
Protection Provided	L-N; L-G; N-G; L-L
Maximum Surge Current Dissipation per Phase*	200 kA PV 200 400 kA PV 400 600 kA PV 600
Nominal Discharge Current (In)	20 kA
Operating Frequency	47-63 Hz
Response Time	<1 nanosecond
Operating Temperature Range	-40° C to +65° C
Operating Humidity (noncondensing)	≤95%
Enclosure	NEMA 3R
Dimensions – H x W x D	24.0" x 16.0" x 8.9" 61.0cm x 41.0cm x 22.4 cm
Weight (Max) lb, kg	60 lbs. / 27 kg.
Certifications	UL 1449 4 th Edition Listed (E315238)

*8 x 20 μsec current wave per ANSI/IEEE C62.41

Model	Product Type	V (Vac)	Phase	Mode(s) @	VPR (Vpk)	In	MCOV
PV-200-120/240-SP PV-400-120/240-SP PV-600-120/240-SP	Type 2 SPD	120/240	1	L-N L-G L-L N-G	1200 1200 1500 1500	20 kA	127/254
PV-200-120/240-SP-D PV-600-120/240-SP-D PV-400-120/240-SP-D	Type 2 SPD	120/240	1	L-N L-G L-L N-G	1500 1500 1500 1500	20 kA	127/220
PV-200-120/208-3Y PV-400-120/208-3Y PV-600-120/208-3Y	Type 2 SPD	120/208	3Y	L-N L-G L-L N-G	1200 1200 1500 1500	20 kA	127/254
PV-200-120/208-3Y-D PV-400-120/208-3Y-D PV-600-120/208-3Y-D	Type 2 SPD	120/208	3Y	L-N L-G L-L N-G	1500 1500 1500 1500	20 kA	127/220
PV-200-277/480-3Y PV-400-277/480-3Y PV-600-277/480-3Y	Type 2 SPD	277/480	3Y	L-N L-G L-L N-G	1800 1800 2500 1800	20 kA	293/508
PV-200-277/480-3Y-D PV-400-277/480-3Y-D PV-600-277/480-3Y-D	Type 2 SPD	277/480	3Y	L-N L-G L-L N-G	1800 1800 2500 1800	20 kA	293/508
PV-200-480-3D PV-400-480-3D PV-600-480-3D	Type 2 SPD	480	3D	L-G L-L	2500 2500	20 kA	593/508
PV-200-480-3D-D PV-400-480-3D-D PV-600-480-3D-D	Type 2 SPD	480	3D	L-G L-L	2500 2500	20 kA	593/508
PV-200-120/208-3Y-1	Type 1 SPD	120/208	3Y	L-N L-G L-L N-G	1000 1000 1500 1200	20 kA	138/239
PV-200-120/208-3Y-1-D PV-400-120/208-3Y-1-D	Type 1 SPD	120/208	3Y	L-N L-G L-L N-G	1000 1000 1500 1200	20 kA	138/239
PV-200-277/480-3Y-1 PV-400-277/480-3Y-1	Type 1 SPD	277/480	3Y	L-N L-G L-L N-G	1500 1500 2500 1500	20 kA	319/552
PV-200-277/480-3Y-1-D PV-400-277/480-3Y-1-D PV-600-277/480-3Y-1-D	Type 1 SPD	277/480	3Y	L-N L-G L-L N-G	1500 1500 2500 1500	20 kA	319/552

PRE-INSTALLATION NOTES

- Please read the entire installation manual before installing this SPD. Unpack unit carefully, removing packing material. Inspect for damages during shipment. If unit seems damaged, contact LEA International. Do not continue to install unit.
- Verify that all nuts, bolts and terminal blocks have good tight connections with clean electrical contact area.
- Every connection should be checked, not just the input terminal blocks. This will ensure the lowest possible contact resistance and best performance.
- Electrical Specification for SPD Installation:
Verify the voltage configuration of the SPD matches actual system voltage configuration of service point. Ground resistance is less than 25 ohms. Make sure all conductors are appropriate for this SPD.

MECHANICAL INSTALLATION

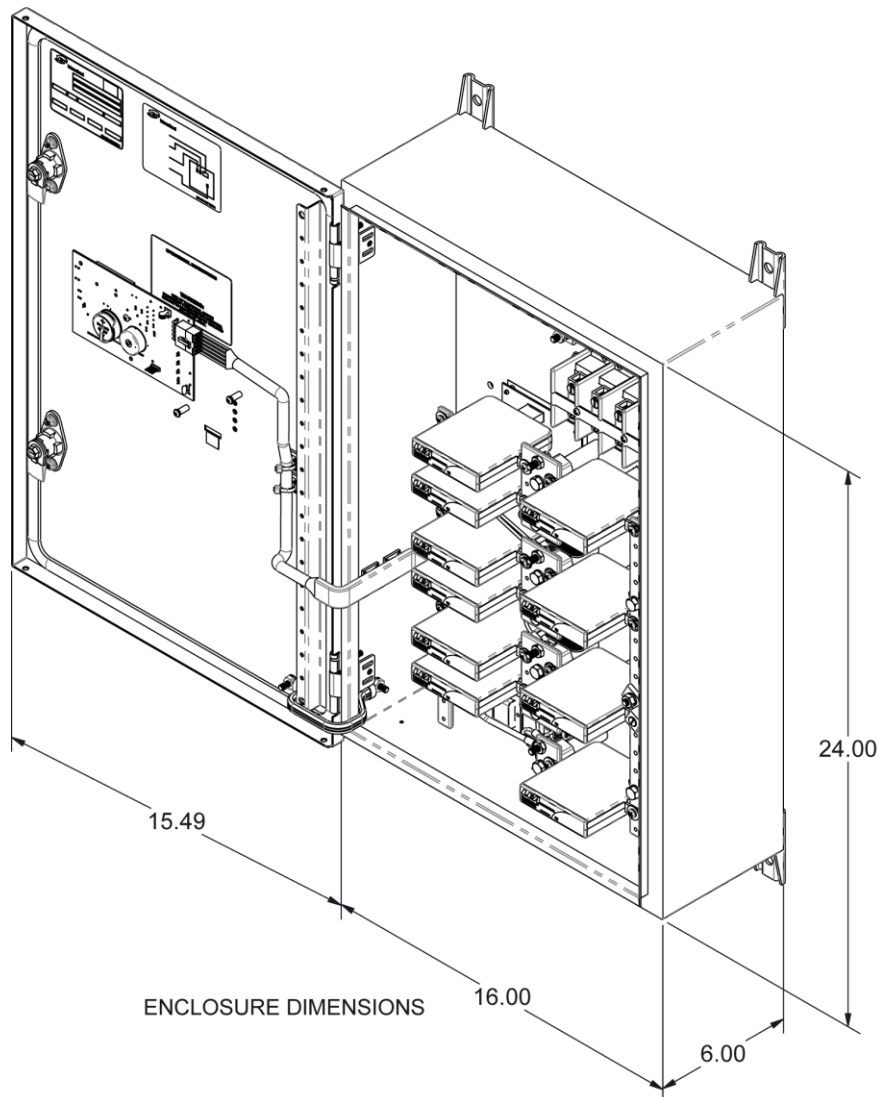

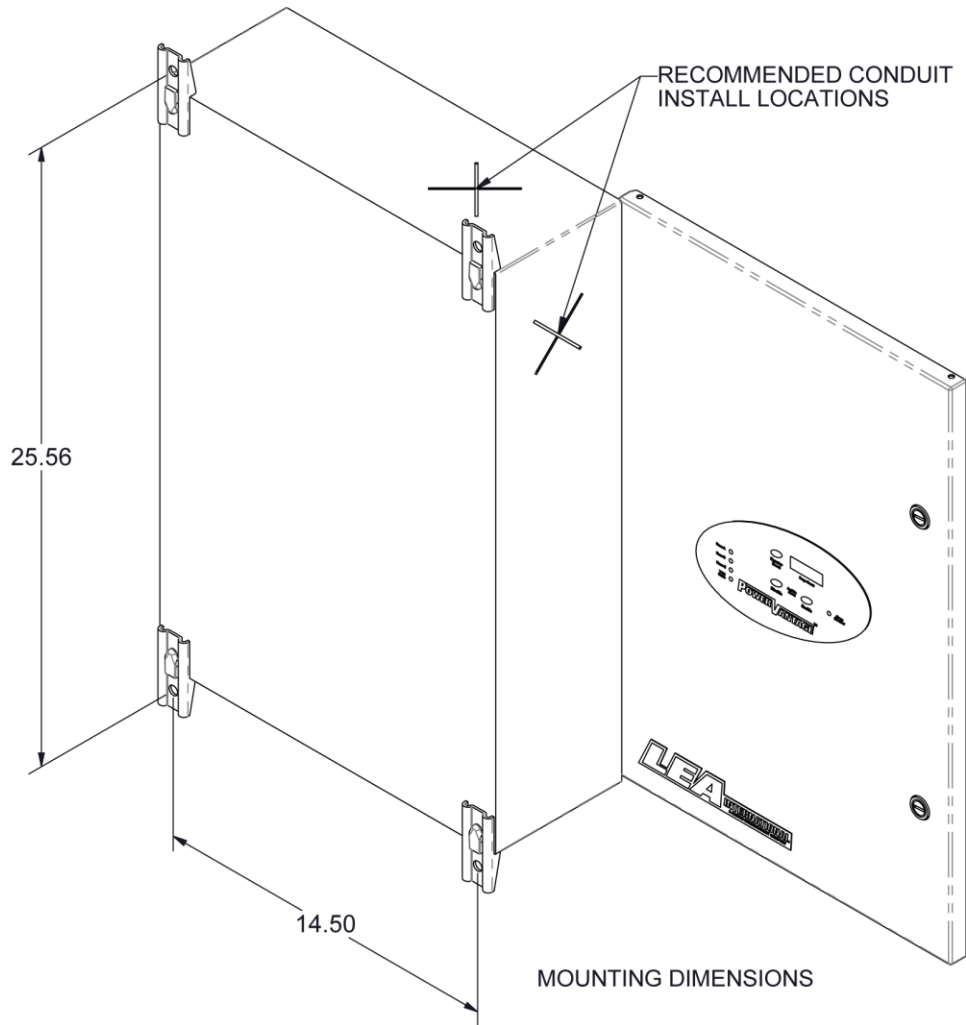

ELECTRICAL INSTALLATION

- **Routing of Connection Leads**

The SPD should be mounted as close as possible to the connection of service point and routed with gradual bends avoiding sharp bends or 90° bends.

- **Length of Leads**

Leads must be as short as possible, not exceeding the recommended length of five feet (5'). Conduit of sufficient size per NFPA 70, National Electrical Code, is intended to enter at the top or on either side near the top of enclosure.

- **Mounting**

The SPD is installed in parallel with the incoming phase conductors. The SPD is mounted using the four corner holes in the enclosure. Each hole is 1/2" in diameter. The mounting holes of the enclosure have a distance in length (from top to bottom) of 22.5" and a distance in width (from left to right) of 14.5".

- **Phase Connection and Conductor Size**

The wire size for the phase conductors should be #14-1/0 AWG. Use of #6 AWG copper minimum is recommended. Connect the phase input wires to the terminals marked Phase 1, Phase 2, or Phase 3 input. It is recommended to connect the SPD to a 60A circuit breaker. This will help when servicing the SPD or replacing modules. An integral switch disconnect may be used; and is ordered as an option. Utilize PVC or aluminum (non-metallic, non-ferrous) conduit with no sharp bends and with a minimum spacing of 4" from the other conductors.

- **Neutral Connection and Conductor Size**

The wire size for the neutral conductor should be #8 to 1/0 AWG. #6 AWG is recommended. The neutral point wire shall be run in the same conduit as the power-input wires and safety ground wires.

- **Ground Connections and Conductor Size**

The SPD provides two types of ground, the safety ground and the transient ground.

- **The safety ground** – The wire size for the safety ground conductor should be #8 AWG to 1/0 wire, #6 AWG is recommended.

Connect the safety ground lug to the existing building safety ground system. This is to equalize back panel potential only. No other connections are made to this lug inside the SPD.

- **The transient ground** – The wire size for the transient ground conductor should be #8 AWG to #1/0 AWG wire, #6 AWG is recommended.

This connection should be made from the transient ground lug to common point earth ground or building steel if it is tied into the facility ground conductor. If a separate ground is driven for the transient ground, it must be tied into the existing ground system.

- **Final Check**

Apply external AC power to the SPD. The SPD is now operational. All LED(s) should be illuminated green. If not, contact LEA International's technical support at 800-882-9110.

- **Visual Inspection**

Operational status of the SPD is verified by observing the status indicator LED(s). Phase A, B, and C status LED "ON" indicate phase input power is applied. The LED(s) illuminated green indicates normal operation with all protection modes functioning. The TVSS status LED illuminated red indicates a failure within the SPD; please call technical support.

To determine if a specific surge module has suffered failure, observe the LED indicators on the PCB Mother board with power applied. A failed module will illuminate red on the mother board.

- **External Indication Lights-** shows loss of power and protection integrity.
- **Internal Protection Indicator Lights of Modules-** redundant monitoring to identify damaged modules for easy servicing.

INSTALLATION PROCEDURE CHECKLIST:

- | | | |
|--------------------------|--------------------------|---|
| YES | NO | |
| <input type="checkbox"/> | <input type="checkbox"/> | The voltage configuration of the SPD matches actual voltage configuration of service point. |
| <input type="checkbox"/> | <input type="checkbox"/> | Ground resistance is less than 25 ohms. |
| <input type="checkbox"/> | <input type="checkbox"/> | All wiring conforms to the national electric code (NEC). |
| <input type="checkbox"/> | <input type="checkbox"/> | All conductors are in accordance with the appropriate layout |
| <input type="checkbox"/> | <input type="checkbox"/> | All lead lengths are as short as possible. |
| <input type="checkbox"/> | <input type="checkbox"/> | The SPD is installed in parallel with the incoming phase conductors. |
| <input type="checkbox"/> | <input type="checkbox"/> | After installation, all lights are illuminated green. |
| <input type="checkbox"/> | <input type="checkbox"/> | All critical loads are protected by the SPD. If not, additional SPD(s) may be required. |

TROUBLESHOOTING

Problem	Solution
Alarm disabled LED is red right after installation	Press the Audible Alarm enable button, it should turn off the red alarm disable LED.
Alarm sound is audible	Silence alarm by using disable button; otherwise use the circuit breaker to disconnect power and silence the alarm. This indicates there was an event which requires checking/replacing inside modules.
Surge counter display is blank	The battery may be defective or dead. Please contact LEA Technical support.
“SPD Status” LED is illuminated red	Disclaimer: Maintenance of electrical devices should be done by trained personnel. Open enclosure door of SPD, reconnect power, and check internal status indication LED(s). At the right side of the set of modules per phase, there are status indication LEDs corresponding to the modules per phase; please investigate if they are illuminated red or if they are off. Disconnect power after LED inspection.

Internal Status indication LED(s) is red	This indicates module needs replacement; turn off the circuit breaker or disconnect switch (reference procedures on pg. 8) or call LEA technical support to check warranty.
Internal Status indication LED(s) are off	This indicates the modules are working properly. If the “SPD Status” in front door is red, then call LEA Technical support.
Power On Phase(s) LED(s) not illuminated	This indicates a loss of power. Please verify power is being supplied to service point; if problem persist, call LEA technical support.

LEA Technical Support is available at 800-882-9110.

MODULE REPLACEMENT PROCEDURE



Disclaimer: Maintenance of electrical devices should be done by trained personnel.



Warning: Before attempting to perform module replacement, **POWER MUST BE TURNED OFF** to the SPD. Failure to do so could result in damage to the SPD or result in electrical shock. Keep hands and clothing clear of energized conductors to reduce the possibility of electrical shock.

1. Identify the modules that need to be replaced. Verify that the replacement, modules are for the same type and rating as the ones requiring replacement before proceeding.
2. Remove input power to the SPD.
3. Remove all mounting hardware and retain for use with the replacement module.
4. Remove the defective module and exchange with the replacement module. Re-verify that the replacement module is of the same type and rating as the one being replaced.
5. Secure replacement module with the mounting hardware removed from the defective module.
6. Reapply input power to SPD. All modules status indicators and enclosure door indicators should illuminate when power is applied.

Spare modules can be ordered from the factory as an option to the original purchases or at a later date. Modules are usually available within 24 hours.

Wiring Diagrams:

The following section contains all layout/installation drawings found within the Power Vantage Family. Locate the appropriate drawing based on the model number of your system.

Single Phase 120/240 (-SP)

Part Numbers

B93-00-2040

B94-00-2040

B93-00-4040

B94-00-4040

B93-00-6040

B94-00-6040

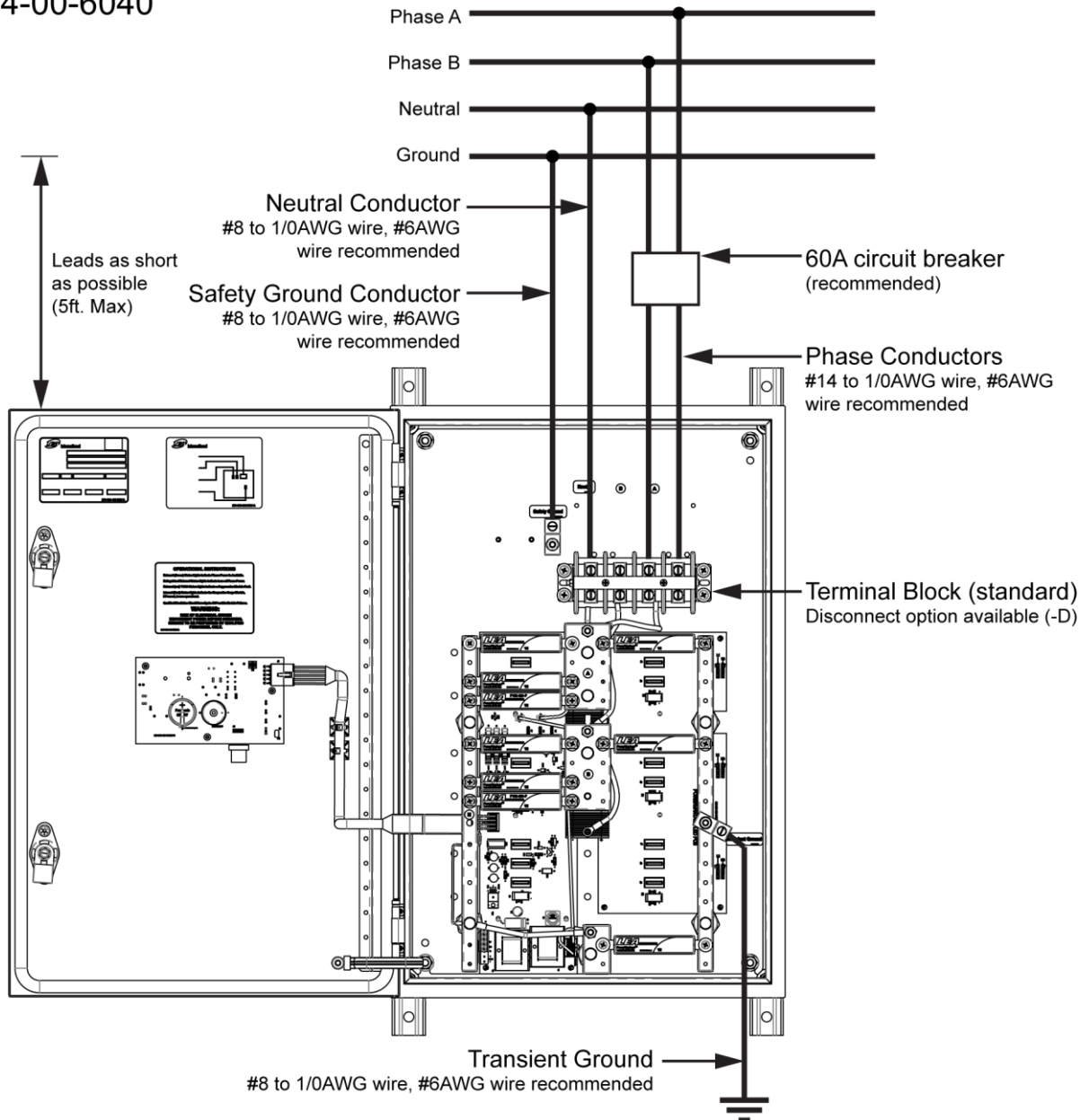

Figure 1

3 Phase Wye (-3Y)

Part Numbers

B93-00-2140	B94-00-2140
B93-00-2740	B94-00-2740
B93-00-4140	B94-00-4140
B93-00-4740	B94-00-4740
B93-00-6140	B94-00-6140
B93-00-6740	B94-00-6740
B93-00-2141	B94-00-2141
B93-00-2741	B94-00-2741
B93-00-4141	B93-00-4741
B94-00-4741	B93-00-6741

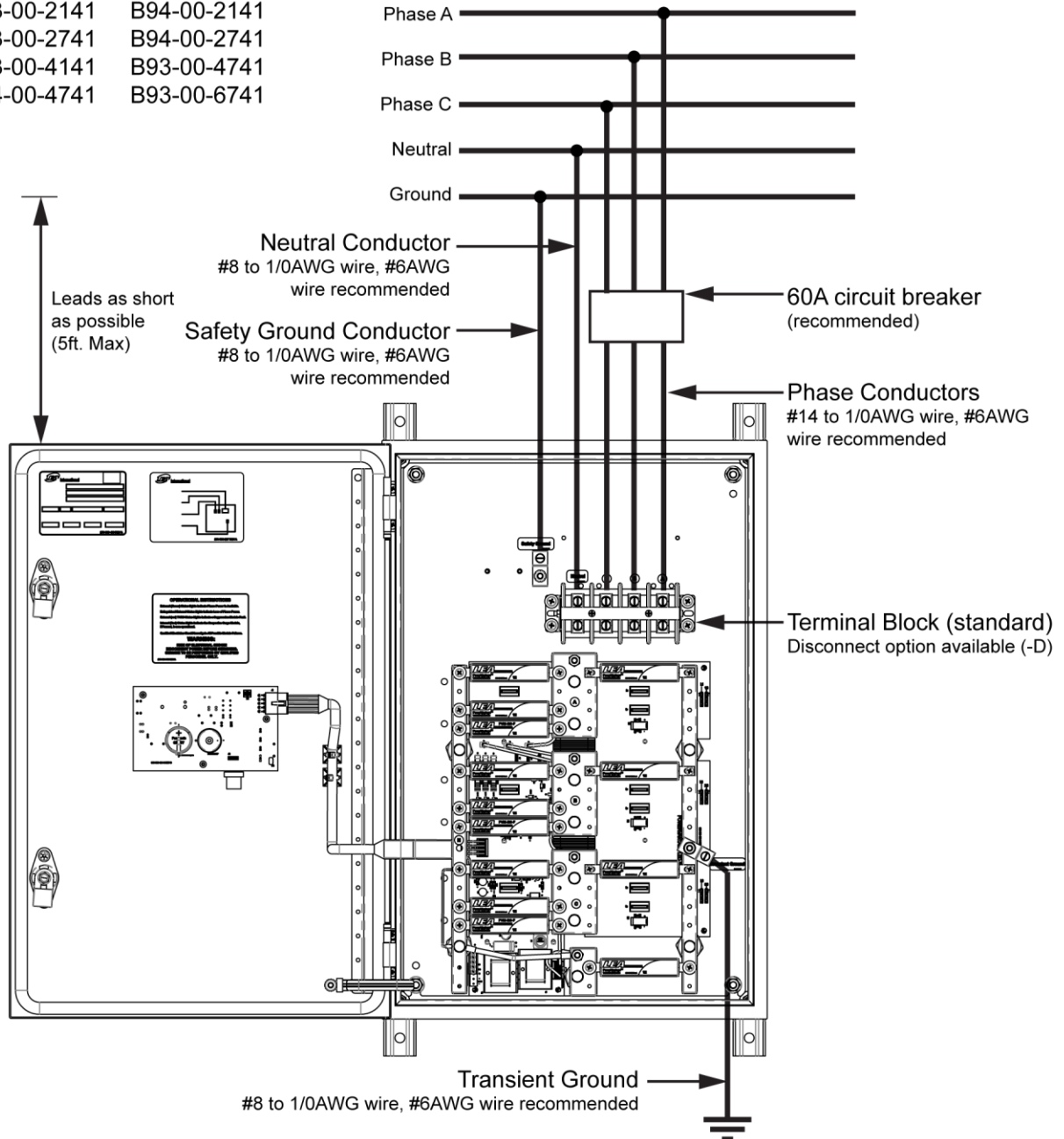

Figure 2

3 Phase Delta (-3D)

Part Numbers

B93-00-2830

B94-00-2830

B93-00-4830

B94-00-4830

B93-00-6830

B94-00-6830

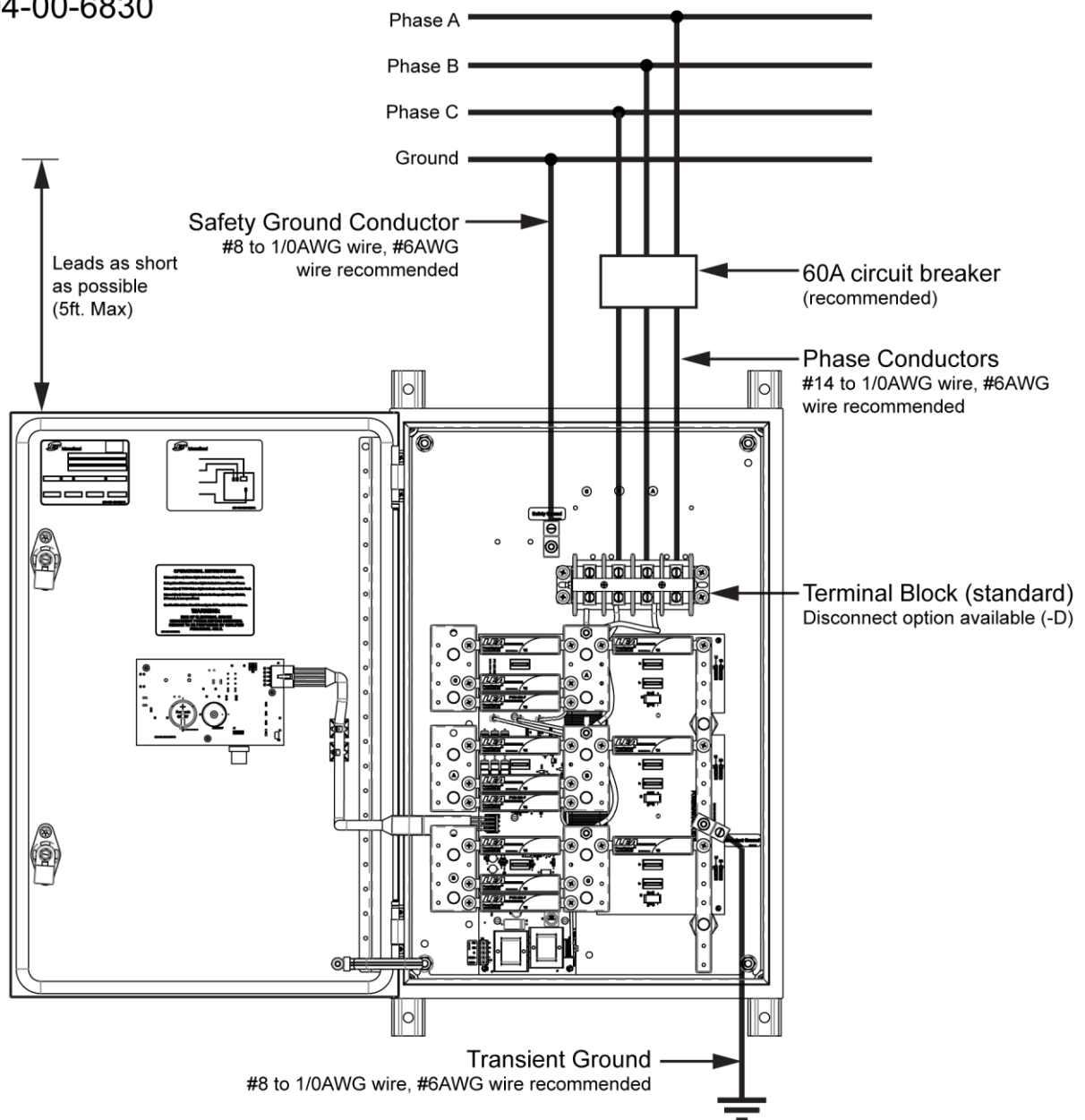

Figure 3

Material Return Policy

No product may be returned without LEA(s) written approval. Transportation charges are to be prepaid by the buyer. Returned item(s) are subject to LEA(s) inspection and acceptance. LEA may, at its discretion, replace any or all return items within a reasonable time after LEA determines that returned item(s) are not in accordance here within; and in such an event, LEA shall not be reliable for any damage arising from the defective delivery or delay caused thereby. When authorized by LEA in writing, unused products may be returned to LEA, subject to service handling, restocking, and if necessary rebuilding charges to "as new" condition.

Call LEA International's customer service department at 800.882.9110 for a return material authorization (RMA) number. No items will be accepted without a RMA number.

Please have the following information on hand when calling for an RMA number:

MODEL NUMBER	FAILURE DESCRIPTION
PART NUMBER	INSTALLATION DATE
PURCHASED DATE	SYSTEM OPERATING VOLTAGE
LEA JOB NUMBER	